

FUTERA FUSION

Condensing High Efficiency Domestic Water Heaters, Pool Heaters and Boilers





Fully Condensing – Ultra Efficient

The gas-fired Futera Fusion™ brings the field-proven performance of Futera Series boilers and water heaters to the ultimate levels of efficiency and reliability.

Fusion's innovative design makes it the ideal choice for applications with low operating, return, or make-up water temperatures. Unlike most condensing products on the market today which publish the highest efficiencies at the lowest inputs, the Fusion can attain efficiencies as high as 99% at full input!

The fully modulating firing system continuously varies the energy input to precisely match the heating load without over-firing and wasting fuel providing extremely high part-load efficiencies.

If you're looking to maximize operating efficiency, reliability, and flexibility in domestic hot water, pool, and hydronic heating applications, the Fusion is your heating solution.

PREMIUM PERFORMANCE & SUPERIOR RELIABILITY

- 97.5% AHRI Certified – up to 99% maximum efficiency
- Full modulation 4:1
- Sealed combustion/direct vent
- Symmetrically air/fuel coupled
- Commercial combustion controls
- Linked operating control system for multiple unit applications
- Gasket-less heat exchanger assembly

OPTIONAL FEATURES

- BACnet or LonWorks interface module
- Cupro-nickel finned tubes
- Freeze protection package
- Honeywell keyboard display Module S7800
- Outdoor sensor with housing
- Outdoor installation
- Knockdown
- Category II Venting



In the interest of product improvement, RBI reserves the right to make changes without notice.

Now Available with PVC & Polypropylene Vent Configurations



FEATURES & BENEFITS

- 500 – 1999 MBH
- Copper 4-pass heat exchanger (160 PSI)
- Stainless steel secondary heat exchanger
- PVC & Polypropylene (PP) Venting
- HeatNet Integrated Boiler Control Platform
- Modulating Temperature Control Mixing Valve
- Variable Speed Blower
- Flame Safeguard
- Flow Switch (Mounted & Wired)
- Integral Primary Pump
- Service Friendly Design





Advanced Heat Exchanger Technology

The Fusion's heat exchanger was designed using the most efficient and dependable heat transfer materials available today. The low-mass, gasket-less primary heat exchanger has solid bronze headers and finned copper or cupronickel tubing for superior heat transfer, resistance to scaling, and protection against thermal shock.

The condensing secondary heat exchanger is solid stainless steel and designed to operate at the boiler's full flow rate. It operates in full condensing mode at all times, while a state of the art temperature mixing system protects the boiler's primary heat exchanger. Each Fusion carries a full non-prorated 20 year

warranty against damage from condensate or thermal shock. There's simply no better way to protect an owner's investment. This design also offers a larger heat transfer surface area than any competitive product

currently available. This translates into the highest available efficiencies – at full operating input! We challenge you to look closely at competing products' efficiency data. No other water heater or boiler on the market has full input efficiencies as high as The Fusion's.



Smart Service Design

Large capacity in a small footprint offers greater flexibility and ease of installation in a space-saving design that leaves more elbowroom in the mechanical room. The rugged structural steel base is designed to fit through a standard 30" doorway. A variety of venting options provides added installation flexibility. Quick-release latches allow for easy access to all components to make short work of service and maintenance.

The Turbo Pilot™: Reliability At Its Best

Futera's independent "Turbo-Pilot" system with UV detection is far more durable and reliable than any competitive ignition system available today.

At 8,000 btu's the "Turbo-Pilot" provides a sure-fire source for burner ignition while providing continuous performance feedback through the HeatNet control platform.

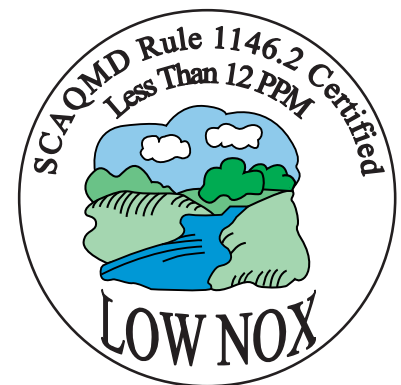
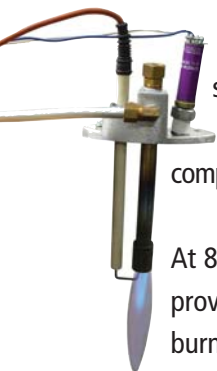



HeatNet controls are built into each Fusion boiler bringing premium efficiency control while providing constant performance communication. HeatNet can communicate with third-party building management systems (BMS) or it can operate independently eliminating the need for wall-mounted BMS systems.

HeatNet maximizes operating efficiency and turndown rates creating substantial energy savings for boiler plants by modulating firing rates to

maximize turndown maintaining peak efficiency regardless of the load.

The control provides flexible operation with a variety of set-up configurations – as a stand-alone unit, units in a Master/Member

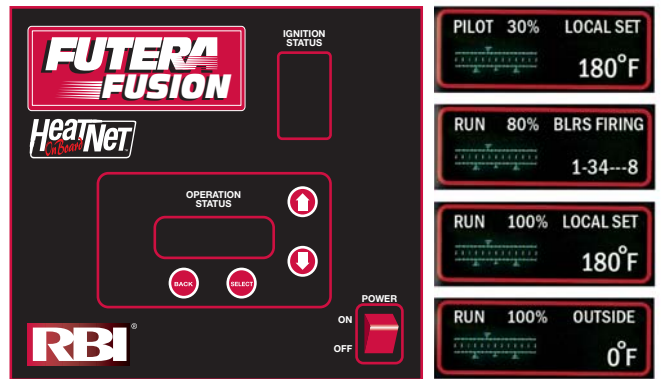

network of up to 16 linked units or as a unit in a typical base-load application.

HeatNet provides higher levels of control, repeatability and feedback through its digital communication platform by monitoring various system characteristics including boiler temperatures, limit circuit inputs and overall system demands.



Space-saving Footprint

The compact footprint of Futera Fusion boilers allows for multiple boiler installations while conserving valuable boiler room space for ease of service and maintenance access.



Symmetric Air/Fuel Coupling

Fusion units operate safely and efficiently at all times by reacting to changes in the air or fuel flow which can compromise combustion. Air/Fuel coupling automatically adjusts to any changes in the environment by reducing input levels to maintain optimum combustion quality while providing the highest degree of safety.

Air/Fuel coupling further increases application flexibility by allowing installation of Fusion units in areas of variable air inlet and gas pressures without compromising safety or performance.

Advanced gas train design monitors and regulates gas input based on combustion air pressure, which in turn provides highly repeatable air/fuel ratio throughout the operating range.

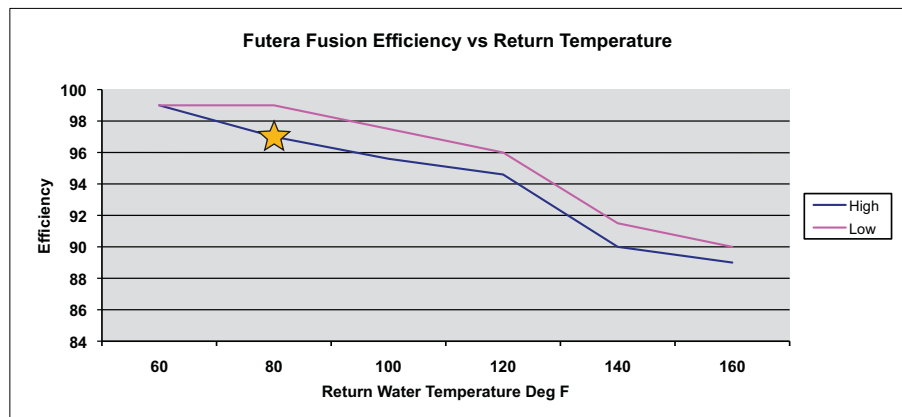
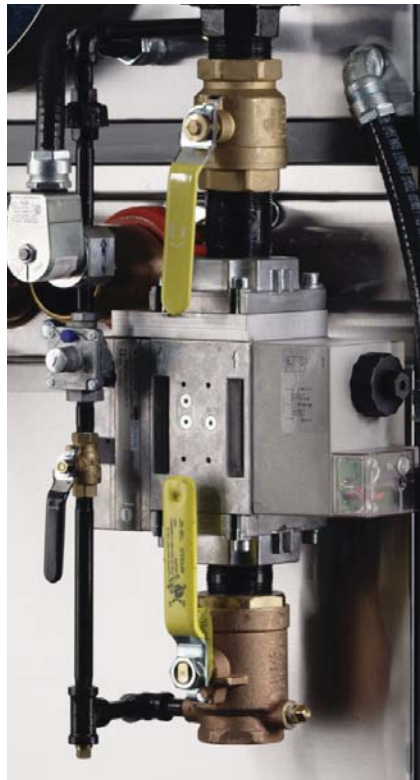

★ 97.5% AHRI Certified Efficiency

Unlike most condensing products available today which publish highest efficiencies at lowest inputs, the Futera Fusion is capable of attaining efficiencies as high as 99% at full input.



7555 Tranmere Dr., Mississauga, Ontario L5S 1L4
Tel. (905) 670-5888 Fax (905) 670-5782

260 North Elm Street, Westfield, MA 01085
Tel. (413) 568-9571 Fax (413) 568-9613

A MESTEK COMPANY www.rbiwaterheaters.com



FUSION 2000

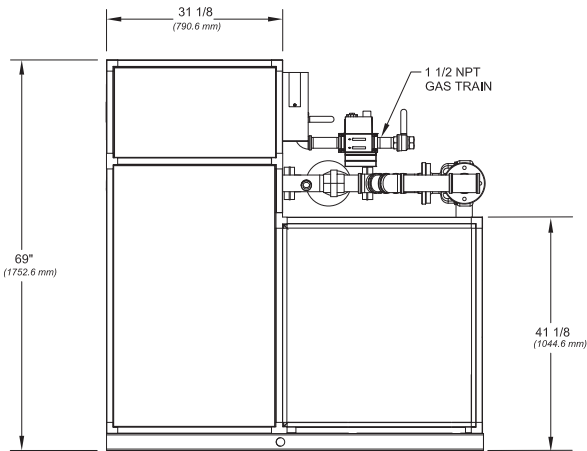

SIDE VIEW

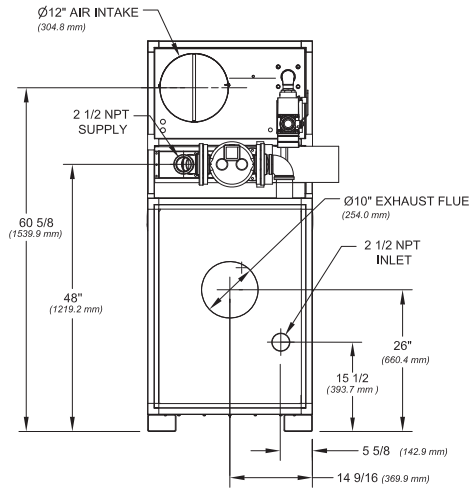

BACK VIEW

DIMENSIONS & RATINGS

Model	Input				Output				Flue Vent			Connections		Weight	
	MBH		kW		MBH		kW		Cat IV Positive (Up to 60')		Air Intake	Gas	Water	Lbs	Kg
	UL Listed Stainless Steel		PVC/PP Option		Negative										
	MBH	kW	MBH	kW	UL Listed Stainless Steel	PVC/PP Option	Negative								
CB/CW 500	500	147	490	144	7"	8"	7"	8"	8"	1"	2"	566	257		
CB/CW 750	750	220	728	213	7"	8"	7"	8"	8"	1"	2"	695	315		
CB/CW 1000	1,000	293	970	284	7"	8"	8"	8"	8"	1 1/4"	2"	705	320		
CB/CW 1250	1,250	366	1200	352	8"	8"	8"	8"	10"	1 1/4"	2 1/2"	800	363		
CB/CW 1500	1,500	440	1440	422	8"	8"	8"	8"	10"	1 1/4"	2 1/2"	863	392		
CB/CW 1750	1,750	513	1663	487	10"	10"	10"	10"	12"	1 1/2"	2 1/2"	1054	478		
CB/CW 2000	1,999	586	1899	556	10"	10"	10"	10"	12"	1 1/2"	2 1/2"	1133	514		

DELTA T / BOILER RECOVERY TABLE – FAHRENHEIT

Inlet Temp (deg f)	Model													
	CB/CW 500		CB/CW 750		CB/CW 1000		CB/CW 1250		CB/CW 1500		CB/CW 1750		CB/CW 2000	
	Flow Rate (gph)	Δt (deg f)	Flow Rate (gph)	Δt (deg f)	Flow Rate (gph)	Δt (deg f)	Flow Rate (gph)	Δt (deg f)	Flow Rate (gph)	Δt (deg f)	Flow Rate (gph)	Δt (deg f)	Flow Rate (gph)	Δt (deg f)
60	621	96	838	106	1062	112	1463	101	1665	106	1847	111	2106	111
80	777	76	1020	86	1278	92	1801	81	2023	86	2218	91	2527	91
120	1611	36	1865	46	2231	52	3502	41	3724	46	3897	51	4452	51

DELTA T / BOILER RECOVERY TABLE – CENTIGRADE

Inlet Temp (deg C)	Model													
	CB/CW 500		CB/CW 750		CB/CW 1000		CB/CW 1250		CB/CW 1500		CB/CW 1750		CB/CW 2000	
	Flow Rate (l/h)	Δt (deg C)	Flow Rate (l/h)	Δt (deg C)	Flow Rate (l/h)	Δt (deg C)	Flow Rate (l/h)	Δt (deg C)	Flow Rate (l/h)	Δt (deg C)	Flow Rate (l/h)	Δt (deg C)	Flow Rate (l/h)	Δt (deg C)
16	2351	53.3	3172	58.9	4020	62.2	5538	56.1	6303	58.9	6992	61.7	7972	61.7
27	2941	42.2	3861	47.8	4838	51.1	6818	45.0	7658	47.8	8396	50.6	9566	50.6
49	6098	20.0	7060	25.6	8445	28.9	13257	22.8	14097	25.6	14752	28.3	16853	28.3